

PCME VIEW 273

ELECTRODYNAMIC™
INSIDE

Indicative

Particulate

Emissions

Monitor



- Reliable indicative measurement of particulate emissions using unique *ElectroDynamic™* Probe Electrification technology
- Satisfies indicative monitoring and recording requirements for dust collectors, according to Local Authority PPC Process Guidance Notes for Part B installations
- *PLUS* version permits multichannel networked system for plant wide monitoring of emissions (1 to 16 sensors)
- Inbuilt data logging for long term emissions and alarm data

System Description

The PCME VIEW 273 is designed for indicative particulate emission monitoring for long term process trending and analysis, where performance approvals are not necessary. Emissions can be scaled to a known reference level, such as during normal bagfilter operation, which allows easy analysis of changes in bagfilter performance and corresponding settings for instant and average alarm levels.

The inbuilt long term data logging calculates and stores emissions averages (uncalibrated) and alarm event data, for satisfying the indicative monitoring and recording requirements for dust collectors, as specified in Local Authority Pollution Prevention and Control (PPC) Process Guidance Notes for Part B installations.

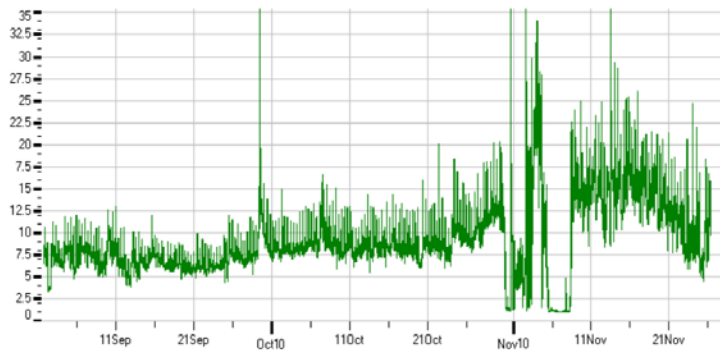

Long term process trend and emissions analysis using PC-ME Dust Tools PC software

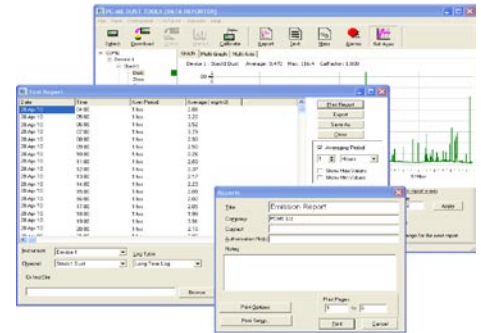

Data Reporter module in PC-ME Dust Tools PC software enables text reporting of long term emission averages.

Alarm Data

The inbuilt alarm log stores all defined alarm events. This data enables storage and reporting of:

- Emission alarms (both instant and average).
- Bag leak detection warning alarms.
- Broken bag detection alarms.

Emissions Reporting

The inclusion of an inbuilt long term data logger allows for:

- Reporting of emission averages for environmental compliance (PC-ME Dust Tools PC software with Data Reporter module).
- Long term process trend analysis for process optimisation and reduced emissions.

Emissions and alarm data is displayed at the control unit and additionally via optional PC-ME Dust Tools PC software with powerful graphing and reporting tools, and remote configuration and backup for single channel or multichannel systems.

Principles of Operation

The instrument uses PCME's unique and patented *ElectroDynamic™* Probe Electrification technology. The sensor electronics measures the current signature created by particles interacting with the grounded sensing rod which protrudes into the stack. The electronics extract a specific frequency band of this signal and electronically filters out the dc current caused by particle collisions. This signal may be correlated to dust concentration by comparison to the results of an iso-kinetic sample for those types of industrial stack applications for which the instrument is designed (see application conditions).

Core features of the *ElectroDynamic™* Probe Electrification technology are that the signal generated is:

- Unaffected by contamination on the sensor rod (which may cause signal drift issues for other systems).
- Not affected by velocity variations within typical bagfilter velocity ranges (see separate TUV approvals for PCME Ltd technology).
- Reliable and stable in the target applications for the instrument (see Process conditions). Identical PCME technology to this is used in TUV and MCERTS approved instruments.

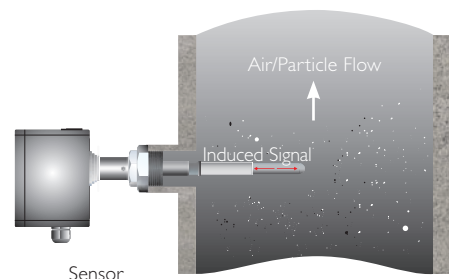

Technology Comparisons and Benefits

Compared to other types of AC systems, *ElectroDynamic™* Systems has the following added benefit:

- An optimised frequency spectrum to extend the velocity range over which the system has no cross sensitivity to changing velocity (see TUV approvals).

Compared to DC triboelectric systems and 'induction sensing and protected probe systems', *ElectroDynamic™* systems have the following added benefits:

- Tolerance to contamination on the rod.
- Stable results and calibrations (protected probes are not necessary in dry applications and therefore drift caused by electrostatic charging effects is avoided).
- Reduced sensitivity to the effects of changing velocity.

product features

Process and Application Conditions

- Indicative (uncalibrated) measurement ranges from 0-10mg/m³ to 0-500mg/m³ (automatic range changes).
- Long term zero drift <0.1mg/m³.
- Recommended maintenance inspection frequency: 6 months.
- For stack measurement but not suitable for electrostatic precipitators or applications with water droplets.
- For use in bagfilter applications with flow of 8-20m/s with no restrictions.

Features

- Expandable up to 16 dust sensors digitally linked to central control unit (**PLUS** version).
 - Alarms (with configurable delay) based on both rolling average data and instantaneous data for reliable plant failure detection and diagnostics.
 - Unique graphics display and data logger (for trend analysis).
 - Inbuilt datalogger for environmental process control.
 - Auto-ranging feature (instrument adjusts dynamic range to track fast moving dust pulses, typically found after reverse jet baghouses) to ensure good measurement.
 - Accepts inputs from analysers for on-board normalisation (T, Oxygen, P). *
 - Secure data and password protection.
 - Integrates with PC-ME Dust Tools reporting and analysis software for on-line control and historical reporting using PC.
 - **PLUS** version available for expansion for up to 16 sensor system.
- *Requires optional Auxiliary Input Module (AIM) unit.

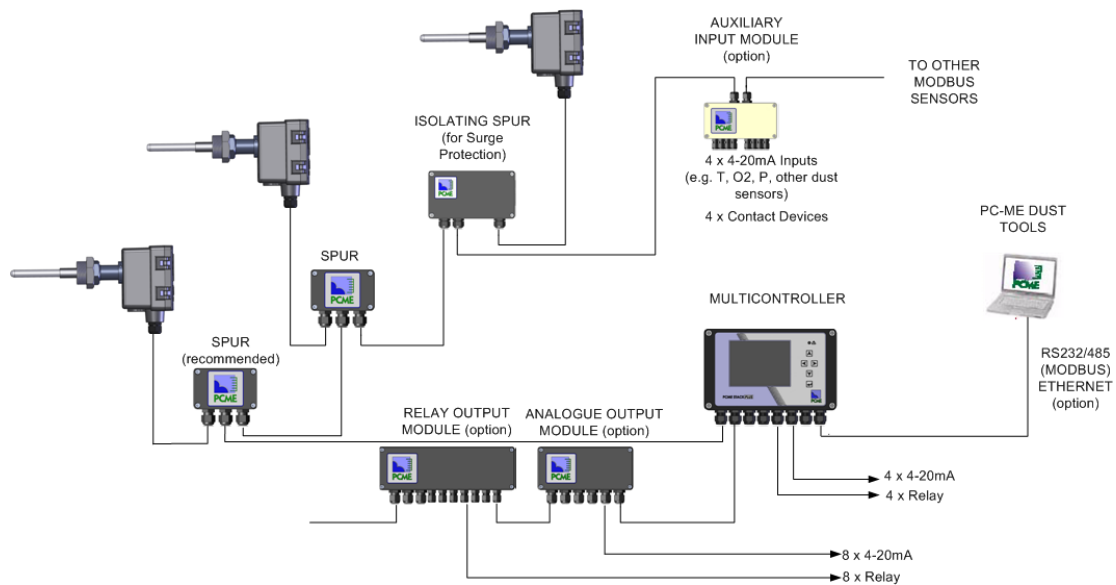

Control Unit Options



Graphics screen shows long term trend

Dust emissions displayed with alarm level

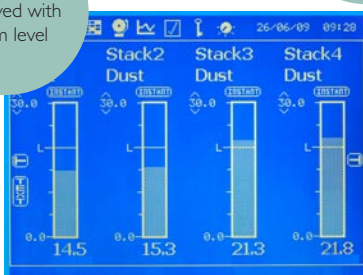

	Standard System	PLUS System
Controller Type	Interface module	MultiController
No of Sensor Channels	1	1-16
ICON Driven Multilingual Menus	Emission and Alarm levels Review data logs Show graph and bar chart Set up and password	Emission and Alarm levels Review data logs Show graphs and multi bar charts Set up and password
Emission Data Logs Long (averages for reporting) Alarms	Capacity stated for 1 sensor 12 months @ 15 minutes 500 entries	Capacity stated for 4 sensors 12 months @ 15 minutes 500 entries
Ethernet Enabled Option	None	Ethernet (Modbus TCP) (optional)
Outputs	1 x RS485 (Modbus RTU) 1 x 4-20mA (500 ohm) 2 x Relay (2A@250V, user selectable)	1 x RS485 (Modbus RTU) 4 x 4-20mA (500 ohm) 4 x Relay (2A@250V, user selectable)
Inputs	1 input for plant off indication, bag cleaning reference and multiple calibrations	4 inputs for plant off indication, bag cleaning reference and multiple calibrations
Enclosure Size (mm)	220 W x 123 H x 80 D	263 W x 160 H x 91 D
Power Supply	100 to 240 VAC (50/60Hz), 1A	100 to 240 VAC (50/60Hz), 1A

Note: Additional 4-20mA and Relay outputs also available from optional accessory components.

specifications

Dimensions

PCME VIEW 273 (back view)

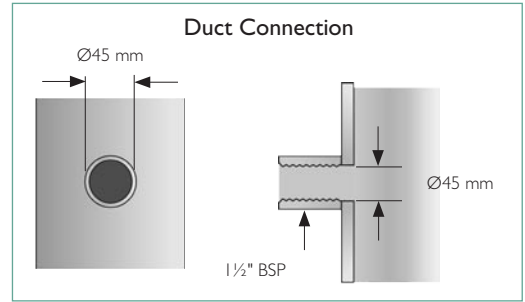
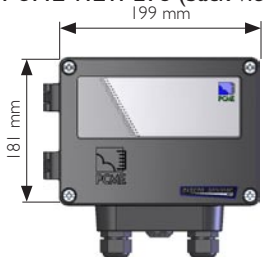

250°C Stainless steel

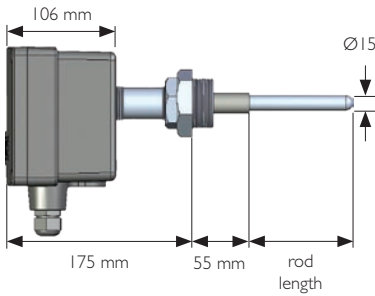

250°C Insulated

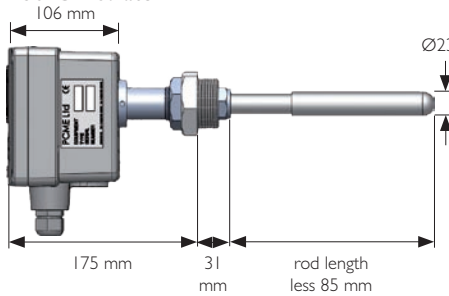

400°C Stainless steel

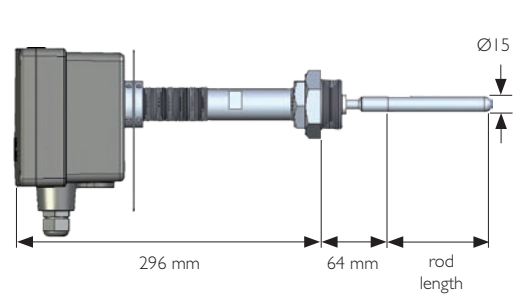

Order Codes

PCME VIEW 273	[single channel]
PCME VIEW 273 PLUS	[multi channel]

Control Unit Options

CON 273 - A B

A	Controller	PLUS version (MultiController) Standard version (Interface Module)	M I
B	Ethernet	None Ethernet fitted (PLUS version only)	0 ET

Example: CON 273

A	B
M	ET

Sensor Options

SEN 273 - 1 2 3 (4)

1	Sensor Type	Standard sensor 0-250°C Insulated sensor 0-250°C Standard sensor 0-400°C	250S 250I 400S
2	Rod Length	0100-1000mm*	RODxxxx
3	ATEX Category ¹	None Category 3 dust (zone 22)	0 X22

*limited to 800mm on 400°C. 1: Not available with insulated sensor.

Sensor Accessories

3	Air filter/regulator	None Standard air purge Standard air purge with basic air filter / regulator Insulated air purge Insulated air purge with basic air filter / regulator	0 AIR-S AIR-S-FR AIR-I AIR-I-FR
---	----------------------	--	---

Example: SEN 273

1	2	3	4
250S	ROD0500	X22	0

System Options

4-core Cable	Specify length required (10m per sensor included as standard)	CAB4
Spur	Divides cable into 2 branches	SPR
Power Supply/Repeater	Voltage and signal boost for extended cabling runs with multiple sensors	PWR
Auxiliary Input Module (AIM)	4 x 4-20mA inputs 4 x Digital inputs	AIM
Analogue Output Module (AOM)	8 x 4-20mA (500 Ohm)	AOM
Alarm Output Module (ROM)	8 x Relay (1A @ 250V)	ROM
Isolating Spur	Provides Surge protection	SPR-X

PC Software Options (PC-ME Dust Tools)

Configuration Options	System Set
Real-time Data Options	Online Predict
Historical Data Options	Data Downloader Data Viewer Data Reporter

About PCME Ltd

As a progressive environmental Company, PCME specialises in particulate measurement for industrial processes. With a worldwide reputation for reliability, innovation and technological excellence, the Company produces equipment for concentration and mass monitoring for regulatory, environmental and process control requirements. A dedicated team of qualified application and sales engineers is always on hand and should be consulted in the selection and usage of the most suitable equipment for any particulate application.

PCME Ltd
Clearview Building
60 Edison Road
St Ives Cambs UK
PE27 3GH

Contact your national or area sales and service office



Tel: +44 (0)1480 468200
Fax: +44 (0)1480 463400
E-mail: contact@pcme.com
www.pcme.com