

Direct insertion type

Zirconia Oxygen Gas Analyzers

Detector type: ZFK8 / Converter type: ZKM

Zirconia oxygen gas analyzer, ideal for combustion control



ZKM2



ZKM1



ZKME



ZFK8



ZFK8

- Modular detector design allows easy field replacement of zirconia element
- Enhanced safety design with integrated and remote power isolation functions
- High-speed response of 4 to 7 seconds
- Explosion-proof case structure available in addition to IP66 and IP67
- You can operate ZKM1 and ZKME without opening the cover.
- Direct insertion system eliminates the need for gas sampling devices

Energy Saving and Environmentally Friendly

Fuji's zirconia oxygen gas analyzers are widely used; not only in industries of high energy consumption, such as steel, power, petroleum/petrochemicals, ceramics, paper/pulp, food, and textile industries, but also in various combustion facilities, such as garbage incinerators and medium-to-small sized boilers, as combustion controllers, achieving a significant energy-saving effect. The oxygen concentration control ensures complete combustion, thus reducing CO₂, SO_x, and NO_x emissions and helping prevent global warming and air pollution.

The transmitter is available in two case structures: IP66 and IP67.



Converter <IP67>
(Type: ZKM2)



Converter <IP66>
(Type: ZKM1)



Zirconia oxygen detector
(Type: ZFK8)

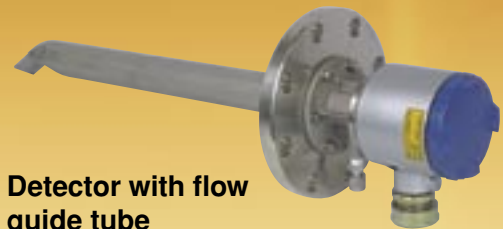

Detector with flow guide tube

Easily replaceable zirconia element



Settings may be made from the front panel without opening the cover



Make the settings from the front panel.

High safety level

- (1) Detecting a break of the thermocouple for heater control in the sensor unit, the analyzer stops the power supply to the detector.
- (2) The power supply to the detector may also be stopped by external contact input in an emergency.
- (3) The key lock function prevents operational errors.

Application 1

Example of measurement in a waste incinerator

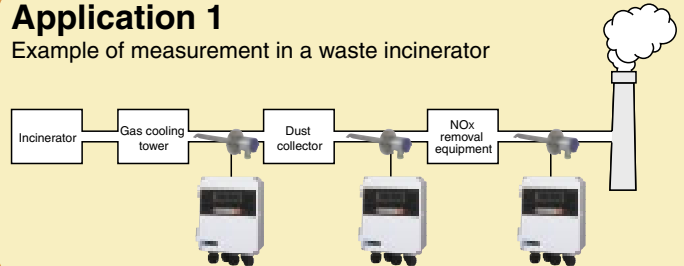

Application 2

Example of boiler combustion control

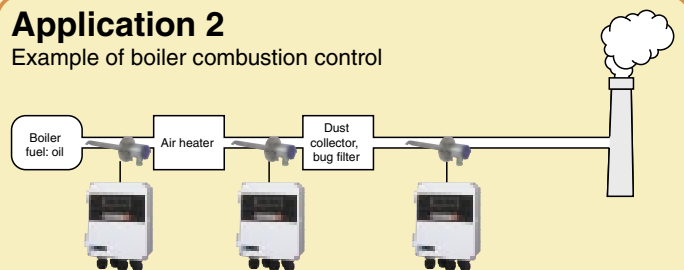

Principle of the detector

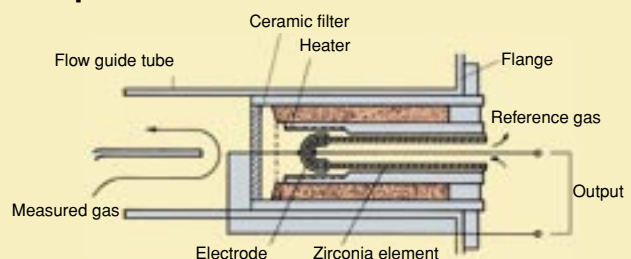

No need for gas sampling devices and a rapid response

Response speed: 4 to 7 sec.

The flow guide tube design ensures a rapid response of 4 to 7 sec.

An ejector is available for high-temperature measurement (up to 1,500°C).

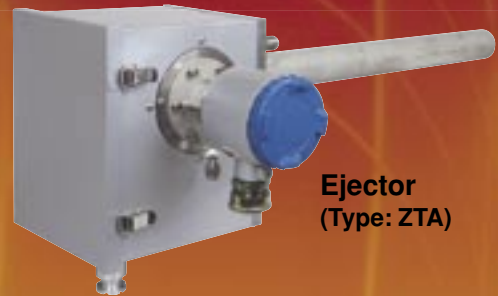
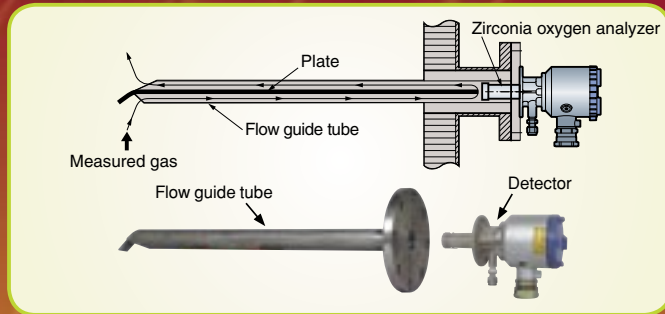

Ejector (Type: ZTA)

Various flow guide tubes, including one with a blow-down nozzle for high particulate levels, and models made of anti-corrosive materials, are available.

System diagram

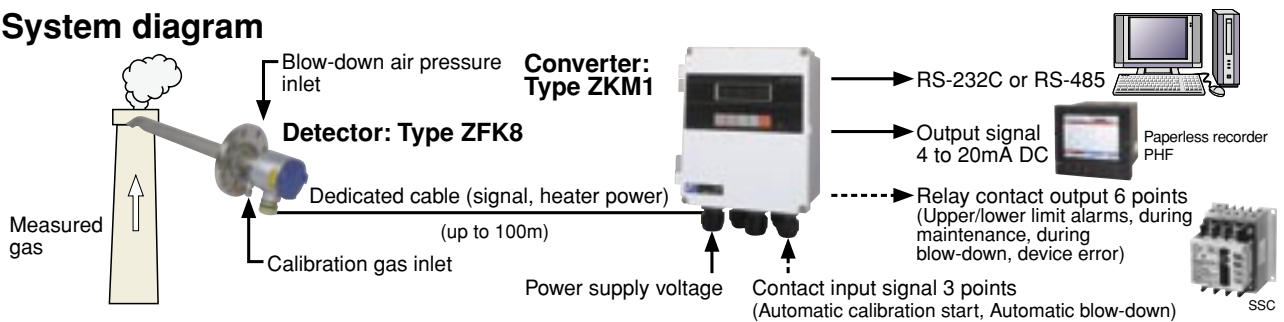

Code symbols

<Detector>

Z F K		8 R								5				1				Description	
1	2	3	4	5	6	7	8	9	10	11	12	13	14	15	16	Cal. gas inlet			
1	2	3	Connection for ϕ 6 mm tube (SUS)													Connection for ϕ 1/4 inch tube (SUS)			
1	2	3	Ball valve																
1	2	3	Power supply													100 to 120VAC 50/60Hz	200 to 240VAC 50/60Hz		
1	2	3	Flow guide tube													flange	application	length	
0	Y	0	None																
5	A	3	SUS304													general use	300mm		
5	A	5	SUS304													general use	500mm		
5	A	7	SUS304													general use	750mm		
5	A	1	SUS304													general use	1000mm		
5	B	3	SUS316													for corrosive gas	300mm		
5	B	5	SUS316													for corrosive gas	500mm		
5	B	7	SUS316													for corrosive gas	750mm		
5	B	1	SUS316													for corrosive gas	1000mm		
5	C	3	SUS316													with blow-down nozzle	300mm		
5	C	5	SUS316													with blow-down nozzle	500mm		
5	C	7	SUS316													with blow-down nozzle	750mm		
5	C	1	SUS316													with blow-down nozzle	1000mm		
6	D	3	SUS316													for high particulate	300mm		
6	D	5	SUS316													for high particulate	500mm		
6	D	7	SUS316													for high particulate	750mm		
6	D	1	SUS316													for high particulate	1000mm		
6	E	3	SUS316													for high particulate with cover	300mm		
6	E	5	SUS316													for high particulate with cover	500mm		
6	E	7	SUS316													for high particulate with cover	750mm		
6	E	1	SUS316													for high particulate with cover	1000mm		
Z	Z	Z	Others																
Y	A		Protection cover													Without	With		
Y	A		Reference air inlet													Non	For ϕ 6mm tube (SUS)	For ϕ 1/4 inch tube (SUS)	
1			Filter spec.													Standard			
J	E	C	Instruction manual language													Japanese	English	Chinese	
1			Specification name plate													Standard (100 to 120V AC 50/60Hz)	Standard (200 to 240V AC 50/60Hz)		

<Converter>

Z K M		1								1				Description									
1	2	3	4	5	6	7	8	9	10	11	12	13	14	15	16	Construction							
1	2	3	IP66													IP67							
1	2	3	Bench type																				
B	E	Z	Output signal													4 to 20mA DC	0 to 1V DC	Other					
1	2		Communication function													RS-232C	RS-485						
Y	1	2	Mounting bracket													None (Specify "None" when the bench type is selected)	Mounting on panel surface	Pipe mounting					
Y	1	2	Optional Functions													None	Combustion efficiency display function Note1)	Blowdown	Auto calibration	Combustion efficiency indication + Blowdown Note1)	Combustion efficiency indication + Auto calibration Note1)	Blowdown + Auto calibration	Combustion efficiency indication + Blowdown + Auto calibration Note1)
J	E	O	Display language													Japanese	English	Chinese					
Y	1	2	Option													None (Specify "None" when the bench type or the auto calibration is selected)	With valve	With valve + flowmeter					

Note1)
When you select this display, K or R type thermocouple is required to measure temperature

<Ejector>

Z T A		1								1				Description						
1	2	3	4	5	6	7	8	9	10	11	12	13	14	15	16	Measured gas temperature				
1	2	For high temperatures (+1500°C max.)													General-use (+800°C max.)					
B	C	D	E	Insertion length [mm]													500	750	1000	1500
1	2	3	4	5	Power supply													100V/115V AC 50/60Hz	200V/220V AC 50/60Hz	230VAC 50/60Hz

<Replacement Detector element>

Power supply	Code symbols
AC100 to 120V	ZFK8YY15-0Y0YY-0YY
AC200 to 240V	ZFK8YY35-0Y0YY-0YY



Flame-proof type available for explosive atmospheres

TIIS Exd IIB T6, NEPSI/Eexd IIC T6 ExII2G



Converter (Type: ZKME)



Zirconia oxygen detector
(Type: ZFKE)

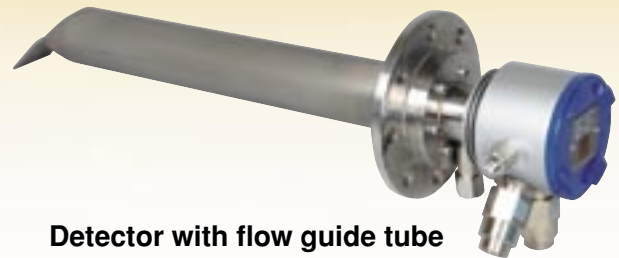

Detector with flow guide tube
(Type: ZFKE)

Code symbols

<Detector>

1	2	3	4	5	6	7	8	9	10	11	12	13	14	15	16	17	Description
Z	F	K	E	R			5						Y			1	Cal. gas inlet Non (G3/8 female screw) For ϕ 6mm tube For ϕ 1/4 inch tube Ejector for ϕ 6mm tube Ejector for ϕ 1/4 inch tube
																	Power supply 100 to 120VAC 50/60Hz 200 to 240VAC 50/60Hz
																	Flow guide tube None <Flange size> JIS 5K 65A JIS 5K 80A JIS 5K100A JIS 10K 65A JIS 10K 80A JIS 10K 100A ANSI 150LB 2B ANSI 150LB 3B ANSI 150LB 4B DIN DN50 PN10 DIN DN80 PN10
																	<Application / material> For corrosive gas / SUS316 With blow-down nozzle / SUS316 For high particular / SUS316 For high particular with cover / SUS316 For high particular / SUS310S For high particular with cover / SUS310S For high particular / titanium For high particular with cover / titanium
																	<Length> 300mm 500mm 750mm 1000mm
																	Reference gas inlet Non (G1/8 female screw) for ϕ 6mm tube For ϕ 1/4 inch tube
																	Filter Standard For high particular
																	Instruction manual language Japanese English Chinese
																	Specification name plate Standard
																	Ex. Standard NEPSI TIIS

<Converter>

1	2	3	4	5	6	7	8	9	10	11	12	13	14	Description
Z	K	M	E											Output signal 4 to 20mA DC 0 to 1V DC
														Communication function RS-232C RS-485
														Optional Functions None Combustion efficiency display function Note1) Blowdown Auto calibration Combustion efficiency indication + Blowdown Note1) Combustion efficiency indication + Auto calibration Note1) Blowdown + Auto calibration Combustion efficiency indication + Blowdown + Auto calibration Note1)
														Instruction manual language Japanese English Chinese
														Mounting Option None (Mounting on panel surface) With valve With valve + flowmeter
														Specification name plate Standard
														Number of Cable Gland 3 4 5 6 7
														Ex Standard NEPSI TIIS

Note1)
When you select this display, K or R type thermocouple is required to measure temperature



<Replacement Detector element>

Power supply	Code symbols
AC100 to 120V	ZFK8YY15-0Y0YY-0YY
AC200 to 240V	ZFK8YY35-0Y0YY-0YY

Specifications

General specifications

Measuring object	Oxygen in non-combustible gas
Measurement method	Direct insertion type zirconia method
Measurable range	Settable within a range from 0-2 to 50 vol%O ₂
Repeatability	±0.5% FS or less
Linearity	±2% FS or less
Zero/Span drift	Within ±2% of full scale/month
Response time	4 to 7 seconds (from the calibration gas inlet)
Analog output	4 to 20mA DC or 0 to 1V DC, insulation
Power supply voltage	100 to 120V AC or 200 to 240V AC

Detector specifications

Measured gas temperature	-10 to +600°C (for the flow guide tube type) -10 to +1500°C (for the ejector type and general type only)
Measured gas pressure	-3 to +3 kPa
Filter	Alumina, quartz paper, SUS316 for explosion-proof type
Structure	Equivalent to ordinary type IP55, or explosion-proof type (as specified)
Weight	Ordinary type: Approx. 1.6 kg (excluding the flow guide tube) Explosion-proof type: Approx. 3 kg (excluding the flow guide tube)

Converter specifications

Measurement concentration display	Digital 4 digits with backlight
Contact output signal	Relay contact output 6 points
Contact input	No-voltage contact 3 points
Communication functions	RS-485 (MODBUS) or RS-232C(MODBUS)
Function	Thermocouple break detection, key lock sensor diagnostic function
Output hold function	Output is held during calibration and blow-down.
Option	Optional combustion efficiency display, blow-down, auto calibration, cock, sensor recovery function, flow meter
Structure	IP66, IP67, or flameproof (as specified)

Flow guide tube specifications

Type	General-purpose, anti-corrosive, with blow-down nozzle, for high particulate concentrations
Length	300 mm to 1,000 mm (as specified)
Mounting flange	JIS5K 65A (80A for high particulate concentrations) For explosion-proof, various types are prepared as specified.

Device Configuration

<General type>

The device to be combined differ according to the conditions of the gas to be measured. Select the devices to be combined with reference to the following table.

Measured gas						Device configuration		
Application	Temperature	Gas Flow	DUST	Protection cover	Note	Detector type	Converter type	Ejector type
General-use (boiler)	600°C or less	5 to 20m/s	Less than 0.2g/Nm ³	—	Fuel: gas, oil	ZFK8R□□5-□A□□□-1□	ZKM	—
			Less than 10g/Nm ³	—	Fuel: coal with blow down	ZFK8R□□5-□C□□□-1□	ZKM	—
For corrosive gas (refuse incinerator)	600°C or less	5 to 20m/s	Less than 1g/Nm ³	—	Contained low moisture	ZFK8R□□5-□B□□□-2□	ZKM	—
			Less than 10g/Nm ³	—	Contained low moisture with blow down	ZFK8R□□5-□C□□□-2□	ZKM	—
			Less than 25g/Nm ³	no	Contained low moisture with blow down	ZFK8R□□5-□D□□□-2□	ZKM	—
			Less than 25g/Nm ³	yes	Contained high moisture with blow down	ZFK8R□□5-□E□□□-2□	ZKM	—
General-use (boiler)	800°C or less	Less than 1m/s	Less than 1g/Nm ³	—	SUS316 tube with blow down	ZFK8R□□5-0Y0□□-1□	ZKM	ZTA2
	1500°C or less	Less than 1m/s	Less than 1g/Nm ³	—	SIC tube with blow down	ZFK8R□□5-0Y0□□-1□	ZKM	ZTA1

<Explosion-proof type>

The device to be combined differ according to the conditions of the gas to be measured. Select the devices to be combined with reference to the following table.

Measured gas					Device configuration	
Application	Temperature	Gas Flow	DUST	Note	Detector type	Converter type
General-use (boiler)	600°C or less	5 to 20m/s	Less than 0.2g/Nm ³	Fuel: gas, oil	ZFKER□□5-□FY□-□□	ZKME
			Less than 10g/Nm ³	Fuel: coa with blow down	ZFKER□□5-□GY□-□□	ZKME
For corrosive gas (refuse incinerator)	600°C or less	5 to 20m/s	Less than 1g/Nm ³	Contained low moisture	ZFKER□□5-□FY□-□□	ZKME
			Less than 10g/Nm ³	Contained low moisture with blow down	ZFKER□□5-□GY□-□□	ZKME
			Less than 25g/Nm ³	Contained low moisture with blow down	ZFKER□□5-□K□Y□-□□	ZKME
			Less than 25g/Nm ³	Contained high moisture with blow down	ZFKER□□5-□L□Y□-□□	ZKME

Note (1) Dust volume is approximate value.

(2) Instrument quality air or bottled air is available as reference air by selecting detector with reference air inlet.

Converter (ZKM1)
<IP66>

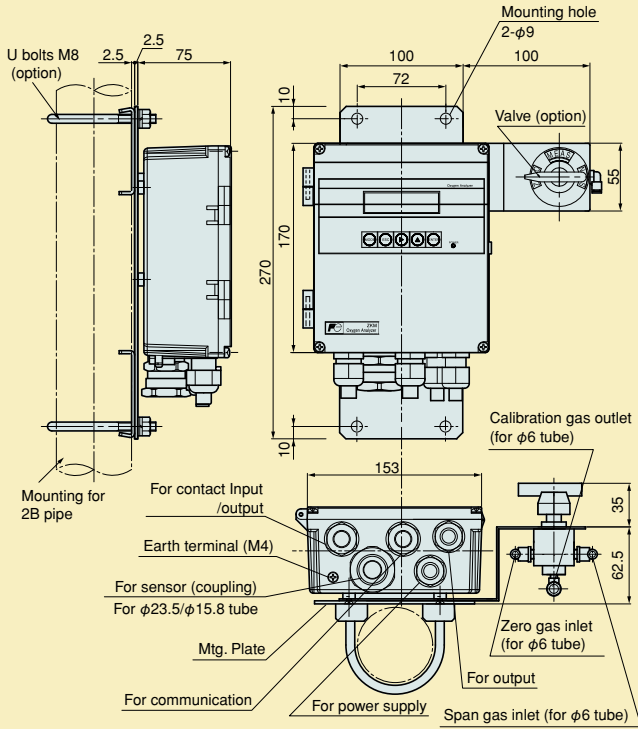

Converter (ZKM2)
<IP67>

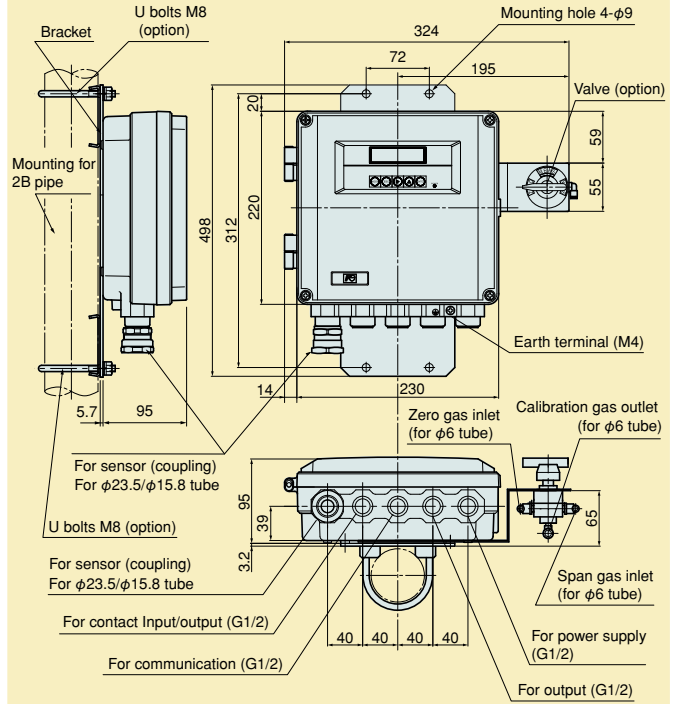

Detector (ZFK8)

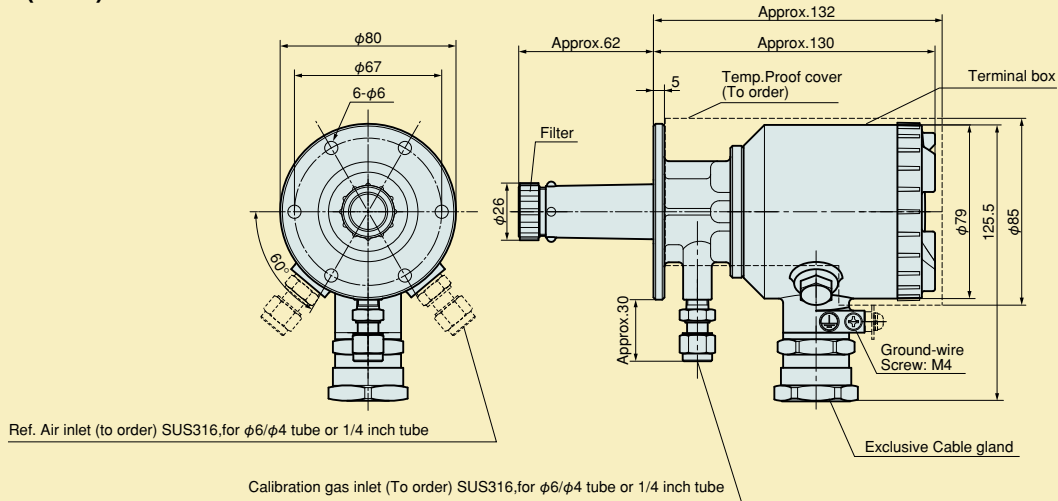

Flow guide tube (Flange size JIS 5K 65A)

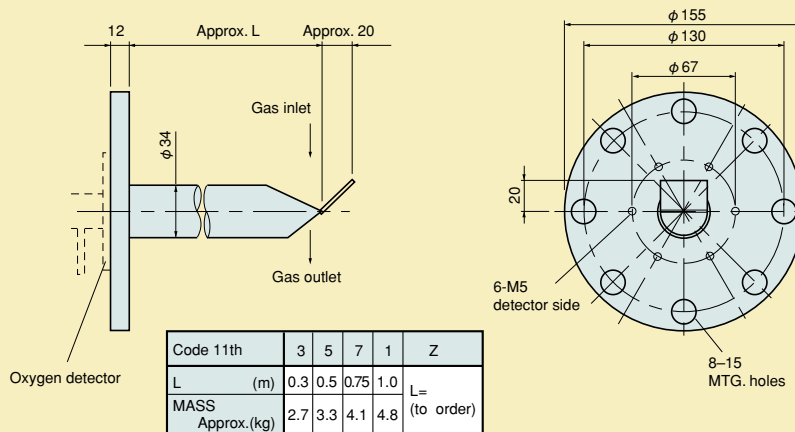

OUTLINE DIAGRAM (Unit: mm)

Converter (ZKME)

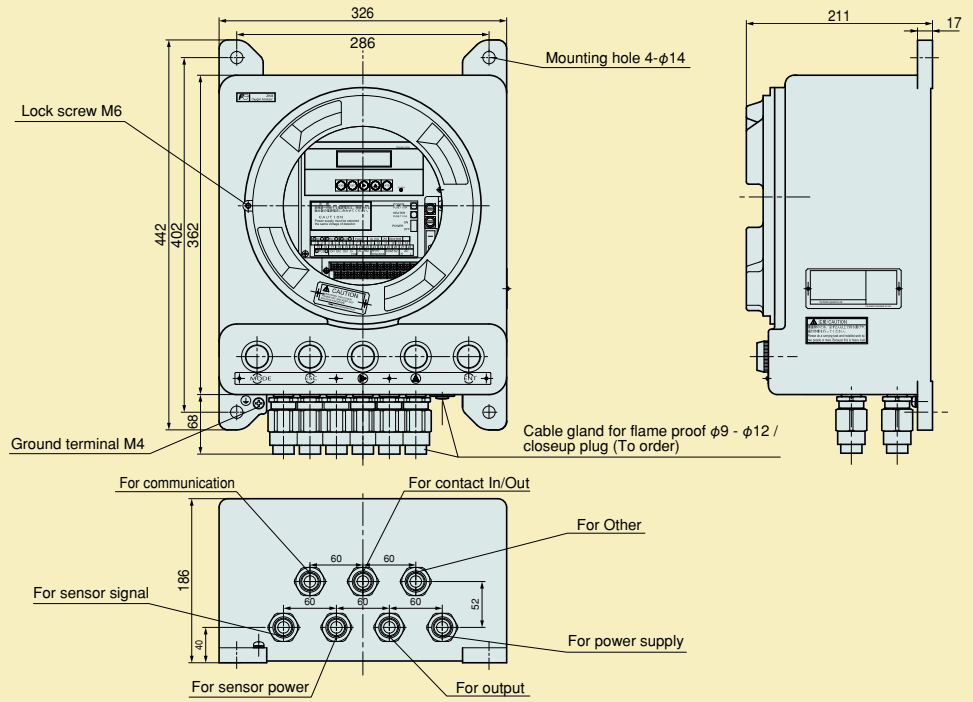

Detector (ZFKER ^Y₁₂)

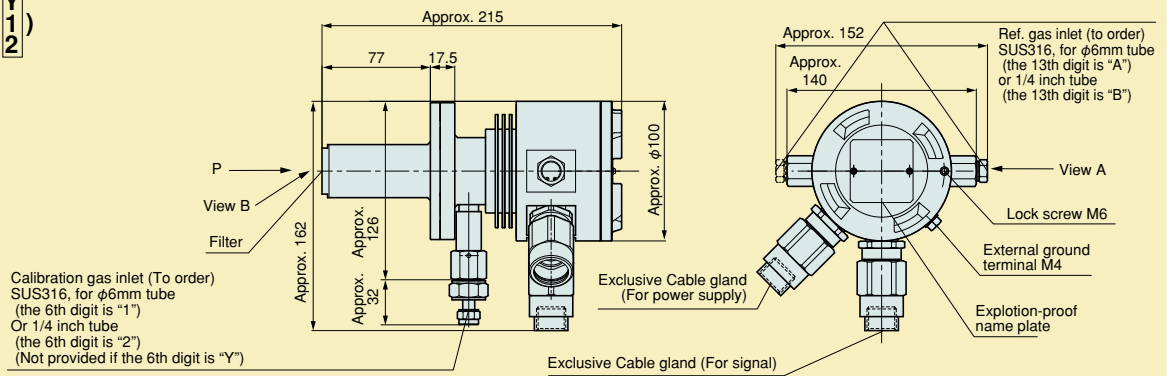

Detector (ZFKER ^A_B)

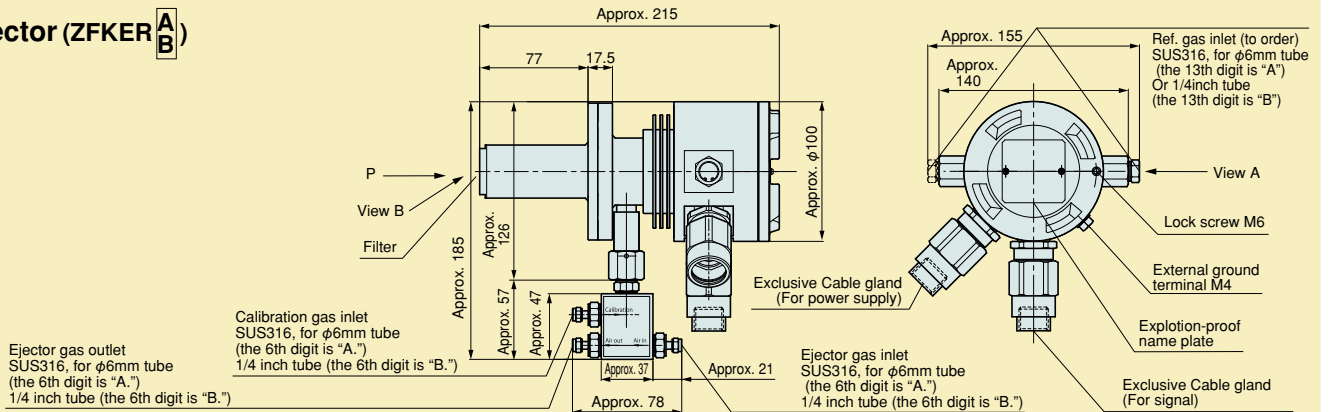

Flow guide tube (Flange size JIS 5K 65A)

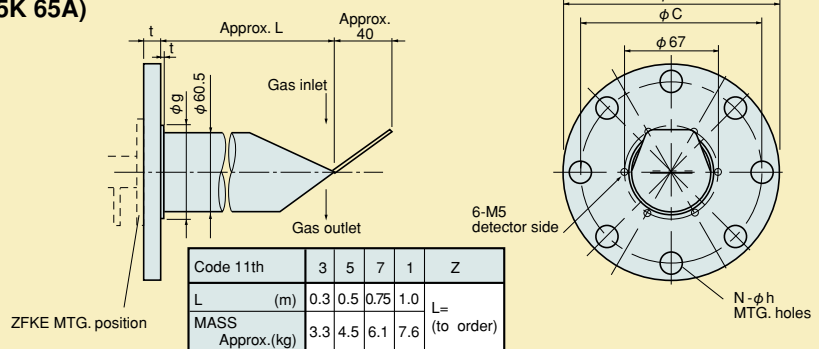

OUTLINE DIAGRAM (Unit: mm)

Ejector (ZTA)

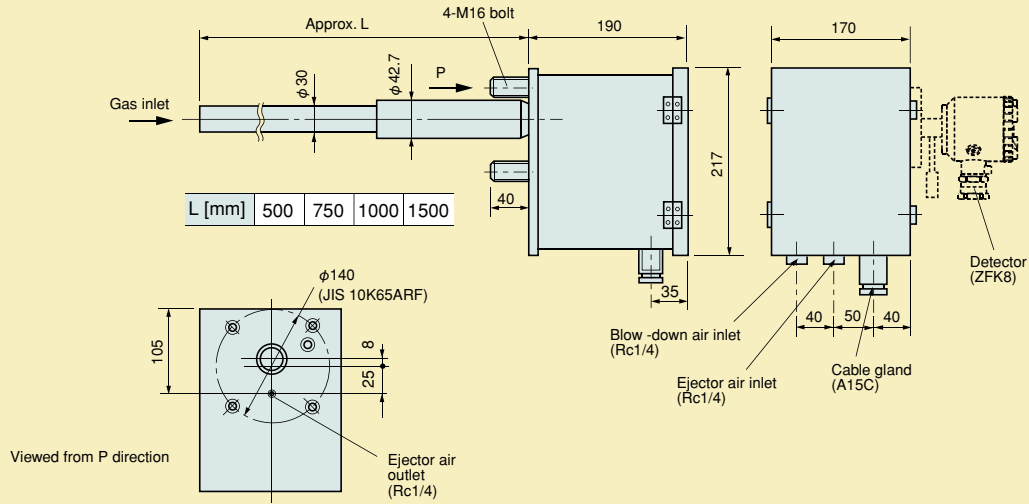

EXTERNAL CONNECTION DIAGRAM

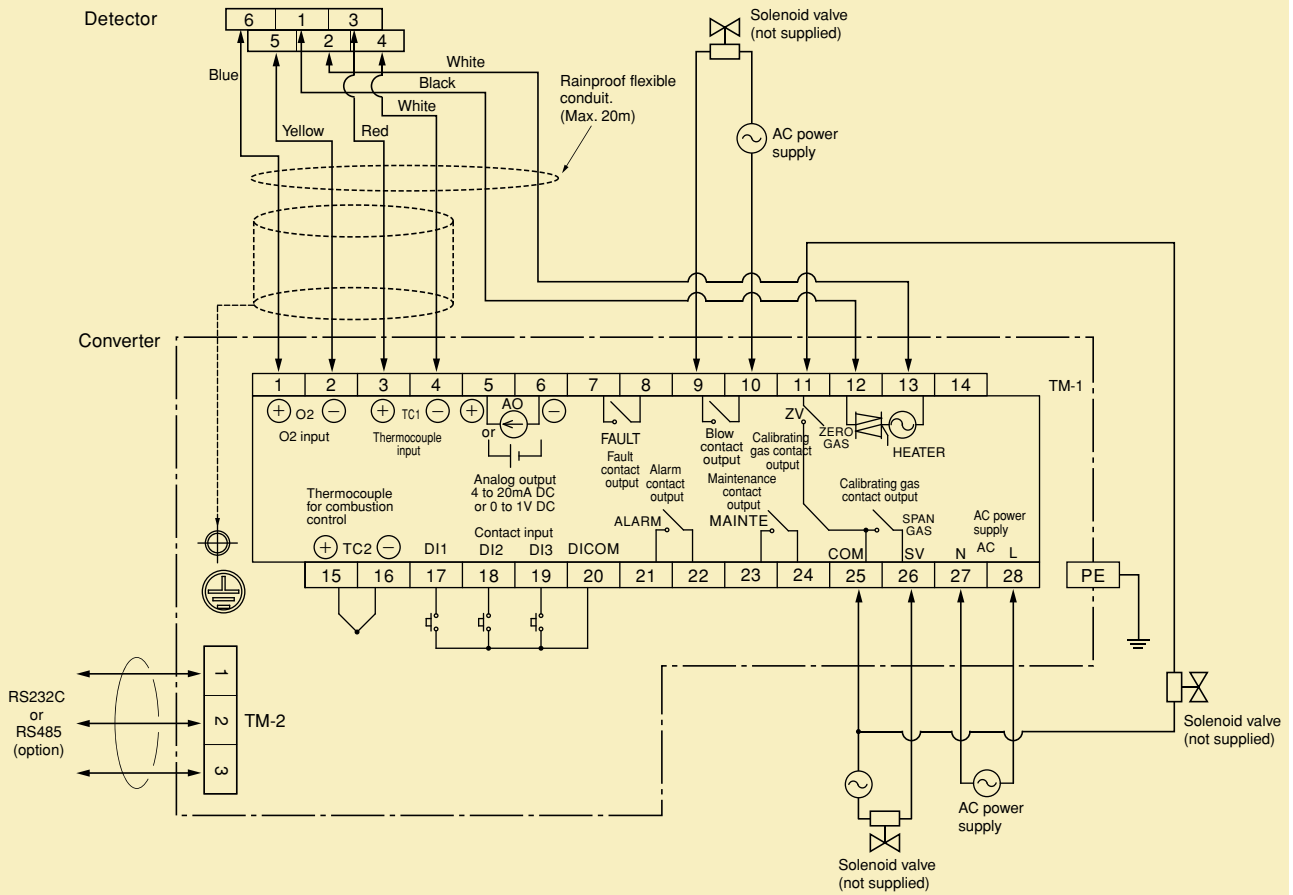

Fuji Electric Systems Co., Ltd.

International Sales Div.1

Sales Group

Gate City Ohsaki, East Tower, 11-2, Osaki 1-chome,
Shinagawa-ku, Tokyo 141-0032, Japan

<http://www.fesys.co.jp/eng>

Phone: 81-3-5435-7280, 7281 Fax: 81-3-5435-7425

<http://www.fic-net.jp/eng>