

Gasmet™ Calibrator



GASMET PORTABLE CALIBRATOR

Gasmet calibrator is one of the most important tools in generating new applications for the Gasmet FTIR Gas Analyzer. The calibrator incorporates a syringe pump, a manual needle valve, a mass flow meter, and a stainless steel injection chamber. The syringe pump injects precise amounts of liquid or gas into a hot nitrogen gas flow, thus producing a continuous flow of a known concentration calibration gas.

The injected liquid is vaporized rapidly in the stainless steel injection chamber, which can be heated up to 180 °C, making the calibrator particularly useful when generating high concentration water vapor calibration gas.

By changing the syringe size, the calibrator can be used to produce homogeneous calibration gas from ppm concentrations up to several percentages (saturated gas).

The GASMET Calibrator is built into a sturdy suitcase. It can be easily transported alongside the Gasmet FTIR Gas Analyzer and the Gasmet Portable Sampling Unit.

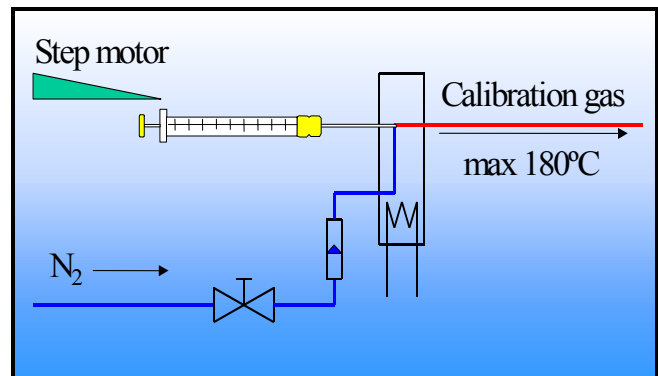

Heated Line

Length: 1 m
Max temperature: 200 °C
Tubing: replaceable PTFE tubes
Tube Size: 4 mm ID

Mass Flow Meter:

Max Gas Flow: 5 l/min
Display: Digital, LCD

Syringe Pump:

Liquid flow: 0.2 µl/h - 400 ml/h
Accuracy: ± 0.5%

Syringe:

Size: 1 ml and 5 ml gas-tight

Heated Injection Chamber:

Max temperature: 180 °C
Material: ss 316

Temperature Controllers (2 pieces)

Model: Cal Controls, CAL 3300

Enclosure

Suitcase: 500 mm * 340 mm * 200 mm
Weight: 12 kg
Mechanical bench: description below

Electrical Connectors:

Power connection: Standard plug CEE-22
Power Consumption: 300 W with 1m heated line

