

# CLD 700 EL ht

Chemiluminescence Analyzer



The CLD 700 EL ht two-channel nitrogen oxides analyzer is the Rolls-Royce model in our product range. It can measure hot, moist sample gas directly from the source and displays the precise NO, NO<sub>x</sub> and NO<sub>2</sub> values.



## A hot subject.

Thanks to the unique «hot tubing», hot gas can be fed to the CLD 700 EL ht directly from the source. Immediately downstream of the hot tubing, the sample gas pressure is reduced to below atmospheric pressure, ensuring that no condensation takes place within the instrument. As a result no damage or inaccuracies occur due to the water vapour in the sample gas. In most applications it is not necessary to use the otherwise customary sample gas cooler.

The EL ht possesses two parallel reactions chambers which permit simultaneous measurement and display of NO, NO<sub>x</sub> as well as NO<sub>2</sub>.

Pressure variations which occur in the sample flow are regulated by a refined, motorized bypass system. The remaining error is compensated for digitally.

By virtue of its measurement performance and technical capabilities, this analyzer satisfies the highest standards whilst leaving nothing to be desired in terms of ease of maintenance.



## Application examples.

Motor vehicle and accessories industry  
Marine engine manufacturing  
Generators  
Incinerators  
Research and development  
Metal processing industry  
Commercial testing and measurement services

This high-performance analyzer can be used either as a stand-alone measurement station or can be integrated into other systems. In brief: wherever it is necessary to measure hot gas directly at the source.

For example, this measurement technique has already been prescribed for the motor industry. In addition, regulations for control and operating procedures have been issued for this industry (the AK protocol agreement). We can supply appropriate firmware.

## Ease of operation.



The user can operate the analyzer by means of the built-in keyboard or through a PC. He is led through the relevant procedure by means of a simple menu structure. The choice of options extends from setting parameters for automatic operation to the switching on and off of individual modules. Error messages appear in full text rather than as code references.



## Specifications CLD 700 EL ht.

<b>Measuring ranges:</b>	0–10/0–100/0–1,000/ 0–10,000 ppm (analog out- put adj.: 25% and 50% FS)	<b>Supply voltage:</b>	230 V/50 Hz, ( $\pm 10\%$ ), optional 115 V/60 Hz ( $\pm 10\%$ )
<b>Minimum detectable concentration:</b>	0.1 ppm	<b>Interface:</b>	RS 232 (standard)
<b>Noise at zero point (<math>1\sigma</math>):</b>	0.05 ppm	<b>Analog output:</b>	selectable 1 V/10 V at 500 k $\Omega$ , 20 mA at 600 $\Omega$ max.
<b>Zero drift:</b>	none	<b>Weight:</b>	40 kg
<b>Linearity (in range):</b>	$\pm 1\%$ FS	<b>Dimensions:</b>	height: 133 mm ( $5\frac{1}{4}$ " ; 3 HU), with feet 158 mm ( $6\frac{1}{4}$ " ) width: 483 mm (19" ) depth: 588 mm ( $23\frac{1}{8}$ " )
<b>Lagtime:</b>	5 sec	<b>Delivery includes:</b>	Analyzer CLD 700 EL ht, vacuum pump, bypass pump, ozone scrubber, power cables, RS 232 cable, analog signal cable, tubing, manual
<b>Rise time (0–90%):</b>	2–32 sec selectable (range dependent)		
<b>Temperature range:</b>	10–40°C		
<b>Humidity tolerance:</b>	5–95% rel. h (non-condensing ambient air)		
<b>Quenching:</b>	for H <sub>2</sub> O: <0.5%/vol.-% H <sub>2</sub> O for CO <sub>2</sub> : <0.1%/vol.-% CO <sub>2</sub>		
<b>Sample flow rate:</b>	1.2 l/min		
<b>Dry air use (for O<sub>3</sub> generator):</b>	0.55 l/min		
<b>Power required:</b>	660 VA		

ECO PHYSICS reserves the right to change these specifications without notice (2005).

## Flow diagram CLD 700 EL ht.

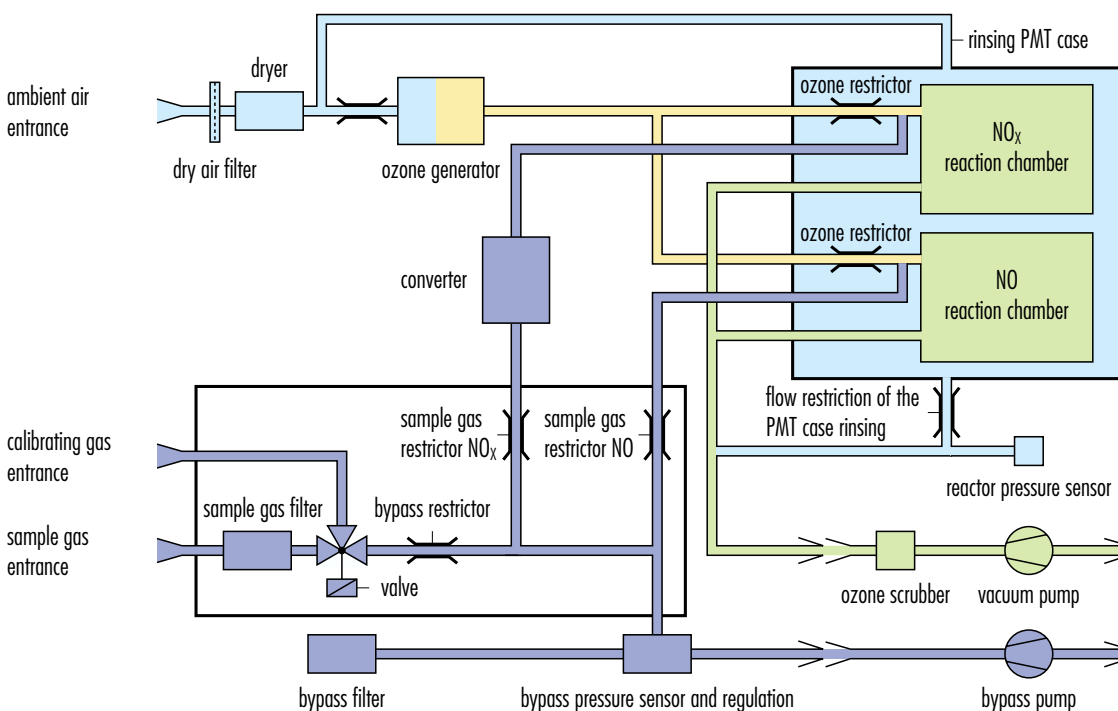

ECO PHYSICS