



Optidew Vision

Precision Dewpointmeter



For laboratory or process humidity measurement with best accuracy and virtually zero drift, Optidew Vision combines latest sensor design with digital control technology.

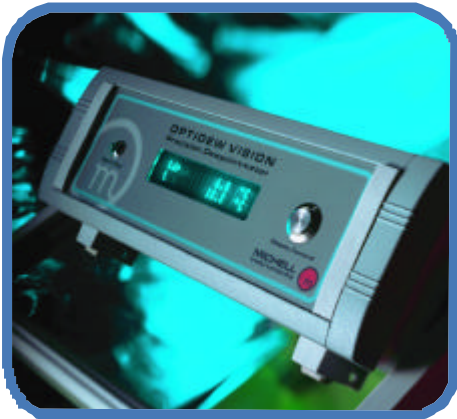

*Optidew Vision
Precision Dewpointmeter*

Setting the Standard

The Optidew Vision Precision Dewpointmeter works on the proven, fundamental optical dew point measurement principle, giving unmatched and drift-free long-term performance. It offers a wide measurement range from the equivalent of less than 0.5% up to 100% rh at ambient temperatures from -40 to +90 °C. Optidew Vision provides a high definition alphanumeric display of the measured humidity, two linear mA outputs and serial communications, allowing set-up and monitoring by a suitable computer or PLC system or via specific Optidew Vision logging software. An adjustable volt-free contact alarm means that Optidew Vision can be used for direct process control.

As an option, a high temperature sensor is available extending the upper measurement limit to 130 °C (see separate datasheet for details). There is also a high pressure version of the Optidew Sensor available (25 MPa / IP 65).

Features

- Fundamental, accurate and drift-free dew point measurement
- High reliability = Low cost of ownership
- Wide range: equivalent to <0.5 to 100% rh from -40 to +90°C ambient
- Weatherproof sensor
- 0.2 °C dew-point accuracy
*0.15 °C optional
- High pressure version to 25 MPa available
- Smart housing with panel-mount option
- Multiple engineering units
- Interchangeable sensor
- Free application software

Laboratory or Process

Optidew Vision's sensor is capable of withstanding most industrial conditions, whilst retaining the performance and sensitivity of a high-level reference hygrometer. Yet it is so easy to use. Simply connect the instrument, power up and Optidew Vision is ready to operate. The sensor is designed to work hard - with a corrosion-resistant gold plated mirror and solid construction. Optidew Vision's Display Unit is provided in a smart bench-top housing with ergonomic carry handle and an optional panel-mounting kit is available for permanent control room installations.

Continuous Measurement

The power and sophistication of the Optidew Vision sensor and its digital control loop electronics, means that there is no need to compromise measurement confidence by adopting a cyclic measurement method. Optidew Vision locks on to the actual dew-point temperature of the gas being measured and stays there - continuously. This means you can be certain your process is always in control, irrespective of fluctuations in process temperature, pressure or humidity conditions.

Supreme Flexibility

Optidew Vision's sensor can be operated with a cable length of up to 30 metres (2m cable supplied as standard but longer lengths available to special order). For convenience, the remote temperature probe is provided with a separate cable to allow positioning at the appropriate process point. A pressure rating up to 25 MPa (2 MPa for standard sensor) makes almost any industrial application possible. Two standard sensor versions are available, with either single or two stage cooling, plus a stainless steel version for high temperature applications.

The table indicates the operating range of each sensor version, in ideal conditions (with an air cooled heat sink to dissipate heat generated by the thermoelectric cooler) and in free-air conditions with no additional heat sinking.

Sensor	Single Stage	Two Stage
Lowest mirror temperature (air cooled heat sink at 21°C)	-34	-45
Lowest dew point measurable (air cooled heat sink at 21°C)	-30	-40
Lowest dew point measurable with no heat sink	-24	-29



The Dew Point Specialists

Measurement Reliability - DCC (Dynamic Contamination Correction)

To alleviate the problems of measurement accuracy due to contamination, Michell has engineered a totally new contamination compensation system for Optidew Vision. Dynamic Contamination Correction (DCC) automatically eliminates any error that may be caused by mirror particulate contamination. DCC is a self-learning system that adapts itself to operating conditions, predicts and reacts to the real requirements for contamination correction to achieve optimum transmitter performance at all times. Although the DCC system is fully automatic, it can be user configured to accommodate your own process conditions. As further protection in extreme conditions, sintered stainless steel or porous membrane guard options are available. Either guard can also be used as a flow limiter in high velocity direct insertion applications.

Applications

Optidew Vision is designed to satisfy a wide range of industrial and laboratory applications from Environmental chamber monitoring and calibration to NOX emission control on combined cycle gas-fired power generation plant. Optidew Vision can be effectively deployed in any situation where precise and continuous measurement of the dewpoint or relative humidity of a process is required.

Technical Specifications

GENERAL

Overall Accuracy ± 0.2 °C dew point; ± 0.1 °C temperature
 ± 0.15 °C dewpoint accuracy optional
Measurement units °C, °F for dew point and temperature; %rh; gm^{-3} ; gkg^{-1} ; a_w ; $r(t-t_{dp})$
Response speed 1 °C sec^{-1}
Power supply 90 to 264V, 47/440 Hz. IEC Connection with integral filter

SENSOR

Operating temp range -40 to +90 °C
 *with optional high temp sensor -20 to 130 °C

Mirror Gold plated copper
Temp measurement 1/3 DIN Class B 4 wire 100 W platinum resistance thermometer 3mm dia x 150 mm long stainless steel probe
Sample flow rate 0.1 to 2 $Nlmin^{-1}$ (in sampling block)
Max velocity 10 $msec^{-1}$ (direct insertion); 30 $msec^{-1}$ (with sintered guard fitted)
Pressure 2 MPa (25 MPa optional)
Cable length 30 metres (max)
Dimensions 126L x 48 dia mm
Weight 0.5 kg

DISPLAY UNIT

Resolution 0.1 for °C, °F and %rh, 0.01 for gm^{-3} and gkg^{-1}
Outputs Analogue: Two 4-20mA or 0-20mA over user selectable range for any parameter.

Operating env -20 to +50 °C ambient; max 98% rh non-condensing
Enclosure option Bench case with carry handle, 230L x 190W x 85H mm. Panel mounting kit
Weight 2.3 kg
Ingress protection IP54 (equivalent to NEMA type 2)
Cable connections 2 metre sensor cable with 10 way bayonet style connector
 2 metre temperature probe cable with weather-proofed circular connector
 Mains cable with IEC connector

Analogue/alarm contacts accessible via two part terminal connector
 Digital communications via 9 way 'D' type connector (installation kit supplied as standard) RS232 cable 9 way D male/female 2 metre cable

OPTIONS

HDPE sensor guard; sensor sampling block; panel-mounting kit; sensor locking nut; Palm PDA logging kit; air cooled heat sink; additional sensor cables up to 30 metres (for cable lengths over 30 metres, please consult the Technical Department); RS485, high pressure sensor

Dimensions

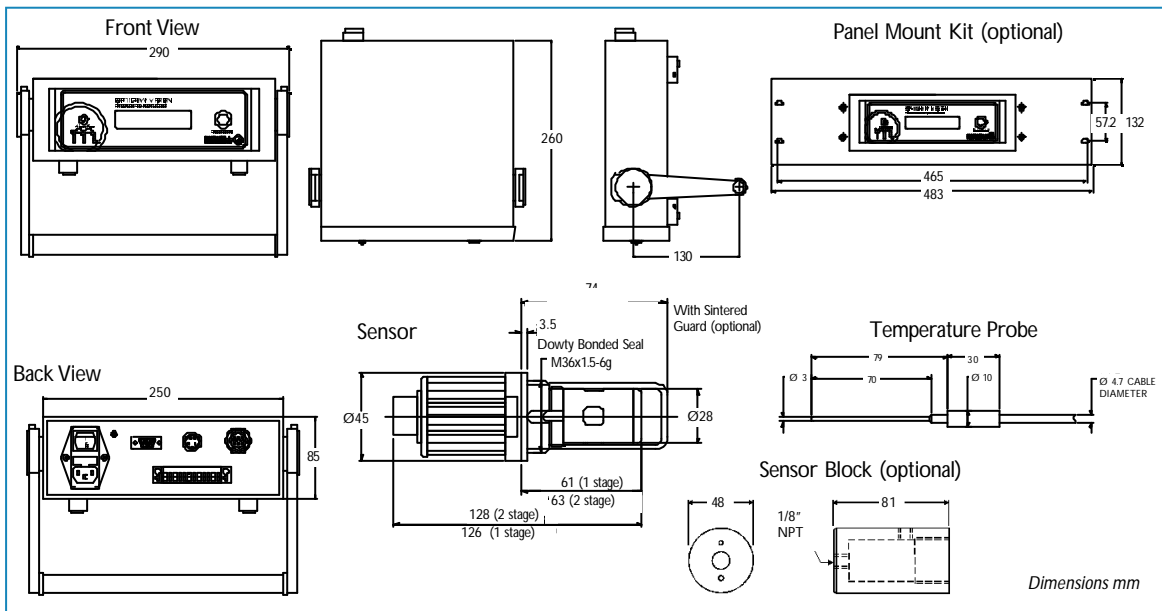

Michell Instruments Ltd
 Nuffield Close, Cambridge CB4 1SS UK
 Tel: +44 (0)1223 434800 Fax: +44 (0)1223 434895
 e-mail: info@michell.co.uk
www.michell-instruments.com



The Dew Point Specialists